

Issue Date:  
June 6, 1995

Revision B  
June 11, 2010

**RECOMMENDATION FOR INTERCHANGEABLE  
STUD BOLTS AND TAP END STUDS  
FOR API SPEC 6A FLANGES**

**TECHNICAL REPORT TR9501  
Revision B**

AWHEM publications may be used by anyone desiring to do so. Every effort has been made by the Association to assure the accuracy and reliability of the data contained in them; however, the Association makes no representation, warranty, or guarantee in connection with this publication and hereby expressly disclaims any liability or responsibility for loss or damage resulting from its use or for the violation of any federal, state or municipal regulation with which this publication may conflict.

**Association of Well Head  
Equipment Manufacturers  
Post Office Box 1166  
Bellaire, Texas 77401**



---

---

## TABLE OF CONTENTS

Section	1.0 General .....	3
	1.1 Purpose .....	3
	1.2 Reference Document .....	3
	1.3 Definitions .....	3
	1.4 Application .....	3
	2.0 Method of calculating stud bolt lengths for type 6B and 6BX flanges .....	4
	2.1 Stud bolt length table for 6B flange connections with "R" and "RX" gaskets .....	5
	2.2 Stud bolt length table for 6BX flange connections .....	6
	3.0 Method of calculating tap end stud lengths for type 6B and 6BX flanges .....	7
	3.1 Tap end stud length table for 6B studded flange connections with "R" and "RX" gaskets .....	8
	3.2 Tap end stud length table for 6BX studded flange connections .....	9
Appendix A - Stud bolt length table for 6B flange connections with "R" gaskets .....		10
Appendix B - Tap end stud length table for 6B studded flange connections with "R" gaskets .....		11

## 1.0 GENERAL

This AWHEM Recommendation compliments and extends but does not conflict with API Spec 6A.

### 1.1 PURPOSE

This AWHEM Recommendation establishes definite dimensions for stud bolts and tap end studs for use with API Spec 6A flanges/studded flange connections and provides for dimensionally interchangeable stud bolts and tap end studs for API Spec 6A flanges/studded flange connections. Stud bolts and tap end studs that may have other lengths etc. for special purposes, and comply with the requirements of API Spec 6A, are beyond the scope of this document.

### 1.2 REFERENCE DOCUMENT

API Spec 6A.

Note: This AWHEM Recommendation derives its basis from API Spec 6A and those standards referenced therein. Any subsequent supplements to API Spec 6A, 17<sup>th</sup> Edition, or subsequent editions issued, shall require review and revision of this AWHEM Recommendation to assure its application.

### 1.3 DEFINITIONS:

#### Length, (Tap End Stud or Stud Bolt) -

Measurement end to end, including points.

#### Length, Nut End Thread -

$2\text{-}1/2 \times \text{Diameter} = \text{Minimum thread length of full threads measured from the end of the stud.}$

#### Length, Tap End Thread -

One diameter + maximum point = minimum thread length, measured from the end of the stud to the end of thread run out (to the last scratch on cut threads, or to the last impression of threads made by other means).

NOTE: The manufacturer shall have and use a means to demonstrate that his threading process produces sufficient full threads on the stud to achieve one (1) diameter of engagement with

the respective tapped holes.

#### Point -

End portion of the stud that features incomplete threads to facilitate thread engagement. The maximum length of the point shall equal 1.5 times the pitch of the thread.

#### Stud Bolts (For Through Bolt Flanges) -

Studs that have threads over their full length or may have an unthreaded portion on the central area of the body diameter.

#### Tap End Studs (For Studded Flanges) -

Studs threaded on each end with an unthreaded portion on the body diameter. The thread length dimension on one end controls the depth that that end will engage into a tapped hole, and also controls the extension length of the stud beyond a studded flange.

#### Threads -

All studs and bolts shall have Class 2A unified inch screw threads per ASME B1.1-1989 (Revision of ANSI B1.1-1982) Standard.

Size 1" and below shall have UNC threads.

Size 1-1/8" and above shall have 8 threads per inch.

### 1.4 APPLICATION

API Spec 6A, "6B" flanges, may use "R" or "RX" gaskets, "RX" gaskets producing greater standoff between flanges. Tables for "6B" flanges in this document show stud bolt and tap end stud lengths that will accommodate both "R" and "RX" gaskets. Some equipment designs provide very little nut and wrench clearance, so occasions may arise when manufacturers or users must install shorter stud bolts or tap end studs when using the "R" gaskets. For this reason, Appendices A and B follow in this document to provide lengths for "R" gaskets only.

## 2.0 METHOD OF CALCULATING STUD BOLT LENGTHS FOR TYPE 6B AND 6BX FLANGES

**2.0a CALCULATION.** The following formula was used in establishing stud bolt lengths listed in the tables and is included here for the convenience of industry. Length shown in tables results from rounding as specified in paragraph 2.0b.

$$L = 2(T + t + d) + S + 2(P)$$

Where:

- L = Calculated stud bolt length.
- T = Total flange thickness.
- t = Plus tolerance for flange thickness.
- d = Heavy hex nut thickness (equals nominal bolt diameter; see ANSI B 18.2.2: Square and Hex Nuts).
- S = Flange face standoff. S = 0 for BX assemblies. See Figure 2.0-1.
- P = Maximum end point height (1.5 x Pitch of thread).

**2.0b ROUNDING OFF PROCEDURE.** If L is 0.010 inch (or more) greater than any 1/4 inch increment, round off upward to the next 1/4 inch increment; if less than 0.010 inch, round off downward to the next 1/4 inch increment.

**2.0c END POINT-HEIGHT OF STUD BOLTS.** The end point is the end portion of a stud bolt beyond the complete thread; and may be chamfered, rounded, or sheared. The maximum height of each end point shall be 1.5 x pitch of thread.

**2.0d FLANGE FACE STANDOFF VALUES, S.** The approximate distance between faces of made-up flanges, S is given in API Spec 6A for R and RX ring gaskets.

Figure 2.0-1

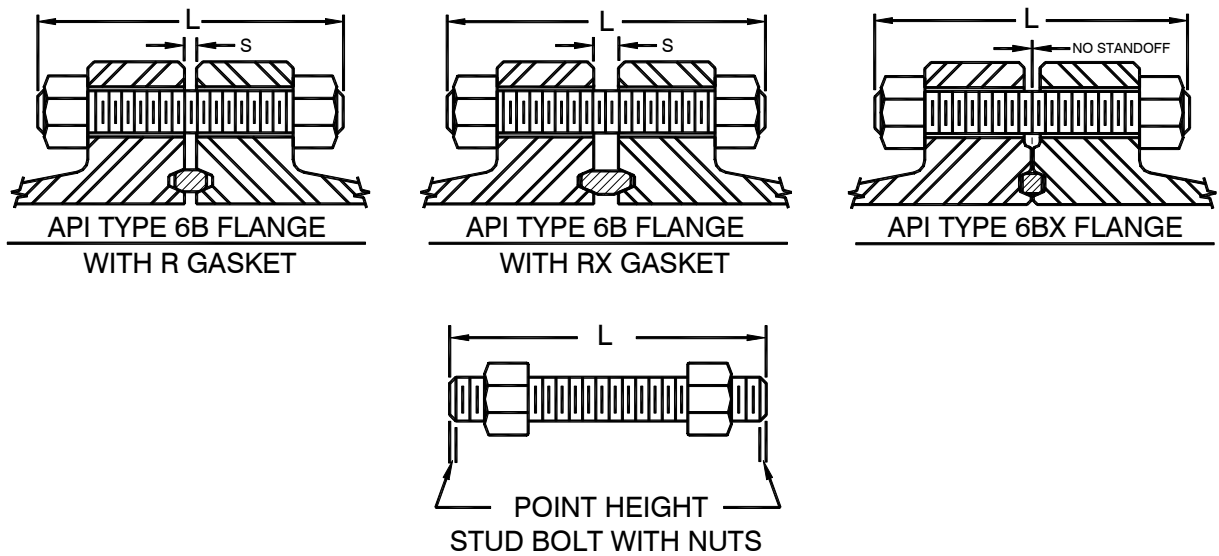

2.1 STUD BOLT LENGTH TABLE FOR 6B FLANGE CONNECTIONS WITH "R" AND "RX" GASKETS

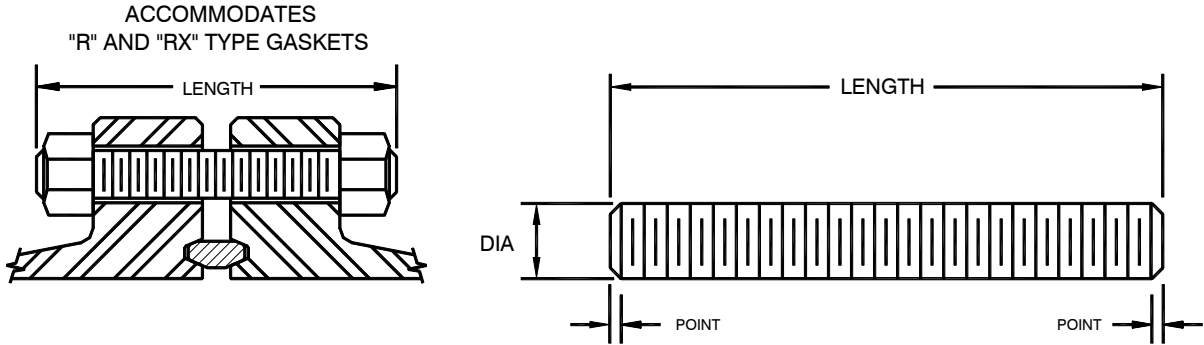

$$\text{LENGTH} = 2(T + t + d) + S + 2(P)$$

- T Total flange thickness.
- t Plus tolerance for flange thickness.
- d Heavy hex nut thickness.
- S Flange face standoff. (with "RX" gasket )
- P Point Max. (1.5 X Pitch)

FLANGE SIZE	BOLT DIA.	LENGTH *	FLANGE SIZE	BOLT DIA.	LENGTH *
2-1/16	2M	0.625	7-1/16	2M	1.000
2-1/16	3M	0.875	7-1/16	3M	1.125
2-1/16	5M	0.875	7-1/16	5M	1.375
2-9/16	2M	0.750	9	2M	1.125
2-9/16	3M	1.000	9	3M	1.375
2-9/16	5M	1.000	9	5M	1.625
3-1/8	2M	0.750	11	2M	1.250
3-1/8	3M	0.875	11	3M	1.375
3-1/8	5M	1.125	11	5M	1.875
4-1/16	2M	0.875	13-5/8	2M	1.250
4-1/16	3M	1.125	13-5/8	3M	1.375
4-1/16	5M	1.250	16-3/4	2M	1.500
5-1/8	2M	1.000	16-3/4	3M	1.625
5-1/8	3M	1.250	21-1/4	2M	1.625
5-1/8	5M	1.500	20-3/4	3M	2.000

\* tolerance on bolt length:  
 + 1/8 , - 0 inch for lengths up to 12 inches.  
 + 1/4 , - 0 inch for lengths over 12 inches.

2.2 STUD BOLT LENGTH TABLE FOR 6BX FLANGE CONNECTIONS

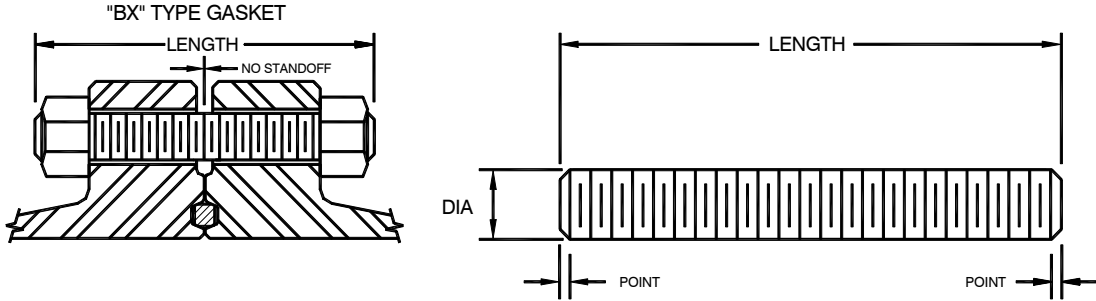

$$\text{LENGTH} = 2(T + t + d) + S + 2(P)$$

- T Total flange thickness.
- t Plus tolerance for flange thickness.
- d Heavy hex nut thickness.
- S Flange face standoff.
- P Point Max. (1.5 X Pitch)

FLANGE SIZE	BOLT DIA.	LENGTH *	FLANGE SIZE	BOLT DIA.	LENGTH *
1-13/16	10M	0.750	11	10M	1.750
1-13/16	15M	0.875	11	15M	2.000
1-13/16	20M	1.000	11	20M	2.750
2-1/16	10M	0.750	13-5/8	5M	1.625
2-1/16	15M	0.875	13-5/8	10M	1.875
2-1/16	20M	1.125	13-5/8	15M	2.250
2-9/16	10M	0.875	13-5/8	20M	3.000
2-9/16	15M	1.000	16-3/4	5M	1.875
2-9/16	20M	1.250	16-3/4	10M	1.875
3-1/16	10M	1.000	18-3/4	5M	2.000
3-1/16	15M	1.125	18-3/4	10M	2.250
3-1/16	20M	1.375	18-3/4	15M	3.000
4-1/16	10M	1.125	21-1/4	5M	2.000
4-1/16	15M	1.375	21-1/4	10M	2.500
4-1/16	20M	1.750	26-3/4	2M	1.750
5-1/8	10M	1.125	26-3/4	3M	2.000
5-1/8	15M	1.500	30	2M	1.625
7-1/16	10M	1.500	30	3M	1.875
7-1/16	15M	1.500			
7-1/16	20M	2.000			
9	10M	1.500			
9	15M	1.875			
9	20M	2.500			

\* tolerance on bolt length:  
 + 1/8 , - 0 inch for lengths up to 12 inches.  
 + 1/4 , - 0 inch for lengths over 12 inches.

### 3.0 METHOD OF CALCULATING TAP END STUD LENGTHS FOR TYPE 6B AND 6BX FLANGES

**3.0a CALCULATION.** The following formula was used in establishing tap end stud lengths listed in the tables and is included here for convenience of industry. Length shown in tables results from rounding as specified in paragraph 3.0b.

$$L = T + t + d + S + P + TL + RF$$

Where:

- L = Calculated tap end stud length.
- T = Total flange thickness.
- t = Plus tolerance for flange thickness.
- d = Heavy hex nut thickness (equals nominal bolt diameter; see ANSI B 18.2.2: Square and Hex Nuts).
- S = Flange face standoff. S = 0 for BX assemblies. See Figure 3.0-1.
- P = Maximum end point height (1.5 x Pitch of thread).
- TL = Tap end thread length, maximum [(one diameter + 1.5 pitch) + 1/16 - 0].
- RF = Add amount of raised face present on studded flanges, if not omitted, to the length of studs in table.

**3.0b ROUNDING OFF PROCEDURE.** Add 1/16 inch to the calculated length and then round up to the next 1/8 inch increment after this addition. This rounding procedure allows for variation in stud installation methods and assures sufficient extension for full nut engagement.

**3.0c END POINT-HEIGHT OF TAP END STUDS.** The end point is the end portion of a stud bolt beyond the complete thread and may be chamfered, rounded, or sheared. The maximum height of each end point shall be 1.5 x pitch of thread.

**3.0d TAP END THREAD LENGTH.** One diameter of tap end stud + 1.5 pitch of thread, +1/16 -0 maximum (this includes point height). See 1.3 Definitions, Length, Tap End Thread.

**3.0e NUT END THREAD LENGTH.** 2.5 x diameter of tap end stud minimum. However if necessary, this length shall be limited to provide minimum unthreaded portion equal to one thread pitch between the tap end threads and nut end threads.

**3.0f FLANGE FACE STANDOFF VALUES, S.** The approximate distance between faces of made-up flanges, S is given in API Spec 6A for R and RX ring gaskets.

Figure 3.0-1

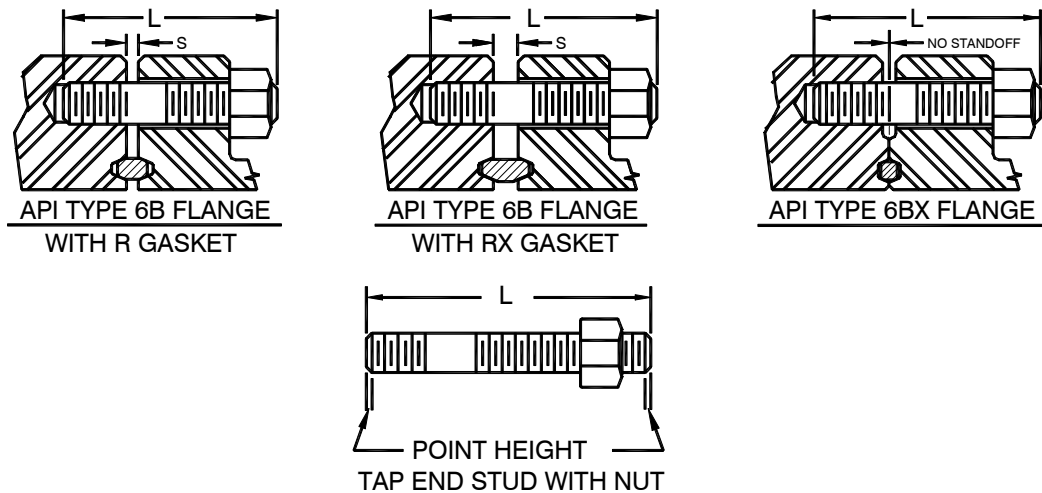

3.1 TAP END STUD LENGTH TABLE FOR 6B STUDED FLANGE CONNECTIONS WITH "R" AND "RX" GASKETS

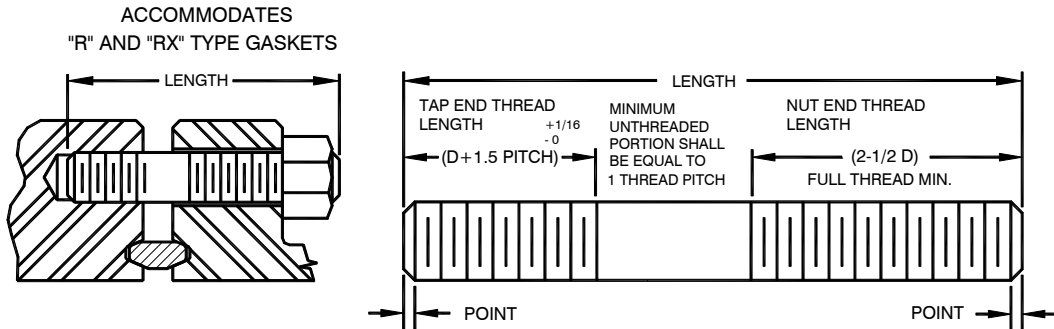

$$\text{LENGTH} = T + t + d + S + P + \text{TL} + \text{RF}$$

- T Total flange thickness.
- t Plus tolerance for flange thickness.
- d Heavy hex nut thickness.
- S Flange face standoff. (with "RX" gasket)
- P Point, maximum (1.5 X Pitch)
- TL Tap end thread length, maximum .  
[(one diameter + 1.5 Pitch) + 1/16 - 0]
- RF Add amount of raised face present on studded flanges, if not omitted, to the length of studs in table.

FLANGE SIZE	STUD DIA.	TAP END * LENGTH	NUT END LENGTH	** LENGTH	FLANGE SIZE	STUD DIA.	TAP END * LENGTH	NUT END LENGTH	** LENGTH		
2-1/16	2M	0.625	0.761	1.563	3.625	7-1/16	2M	1.000	1.188	2.500	5.375
2-1/16	3M	0.875	1.042	2.188	4.625	7-1/16	3M	1.125	1.313	2.813	5.875
2-1/16	5M	0.875	1.042	2.188	4.625	7-1/16	5M	1.375	1.563	3.438	7.500
2-9/16	2M	0.750	0.900	1.875	4.000	9	2M	1.125	1.313	2.813	5.875
2-9/16	3M	1.000	1.188	2.500	5.125	9	3M	1.375	1.563	3.438	6.750
2-9/16	5M	1.000	1.188	2.500	5.125	9	5M	1.625	1.813	4.063	8.500
3-1/8	2M	0.750	0.900	1.875	4.125	11	2M	1.250	1.438	3.125	6.500
3-1/8	3M	0.875	1.042	2.188	4.625	11	3M	1.375	1.563	3.438	7.000
3-1/8	5M	1.125	1.313	2.813	5.625	11	5M	1.875	2.063	4.688	9.625
4-1/16	2M	0.875	1.042	2.188	4.625	13-5/8	2M	1.250	1.438	3.125	6.625
4-1/16	3M	1.125	1.313	2.813	5.500	13-5/8	3M	1.375	1.563	3.438	7.375
4-1/16	5M	1.250	1.438	3.125	6.125	16-3/4	2M	1.500	1.688	3.750	7.500
5-1/8	2M	1.000	1.188	2.500	5.250	16-3/4	3M	1.625	1.813	4.063	8.375
5-1/8	3M	1.250	1.438	3.125	6.000	21-1/4	2M	1.625	1.813	4.063	8.375
5-1/8	5M	1.500	1.688	3.750	7.375	20-3/4	3M	2.000	2.188	5.000	10.125

\* tolerance on tap end thread length:  
+ 1/16 , - 0 inch, See 1.3 Definitions, Length, Tap End Thread.

\*\* tolerance on tap end stud length  
+ 1/8 , - 0 inch



3.2 TAP END STUD LENGTH TABLE FOR 6BX STUDDED FLANGE CONNECTIONS

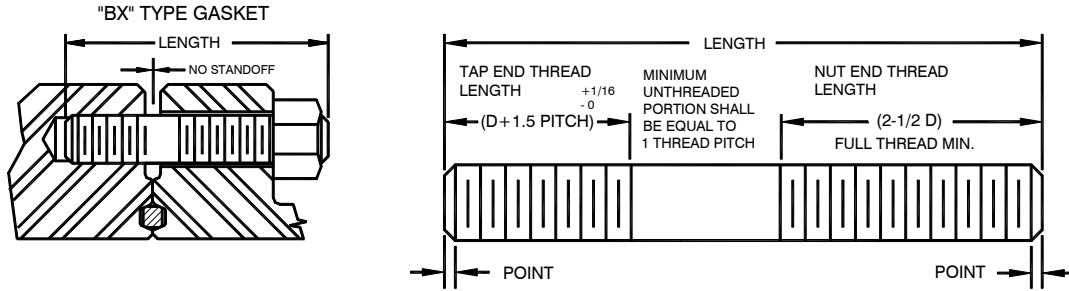

LENGTH = T + t + d + S + P + TL + RF

- T Total flange thickness.
- t Plus tolerance for flange thickness.
- d Heavy hex nut thickness.
- S Flange face standoff.
- P Point, maximum (1.5 X Pitch)

- TL Tap end thread length, maximum [(one diameter + 1.5 Pitch) + 1/16 - 0]
- RF Add amount of raised face present on studded flanges, if not omitted, to the length of studs in table.

FLANGE SIZE	STUD DIA.	TAP END * LENGTH	NUT END LENGTH	** LENGTH	FLANGE SIZE	STUD DIA.	TAP END * LENGTH	NUT END LENGTH	** LENGTH		
1-13/16	10M	0.750	0.900	1.875	3.750	11	10M	1.750	1.938	4.375	9.750
1-13/16	15M	0.875	1.042	2.188	4.125	11	15M	2.000	2.188	5.000	12.000
1-13/16	20M	1.000	1.188	2.500	5.125	11	20M	2.750	2.938	6.875	15.000
2-1/16	10M	0.750	0.900	1.875	3.875	13-5/8	5M	1.625	1.813	4.063	8.375
2-1/16	15M	0.875	1.042	2.188	4.375	13-5/8	10M	1.875	2.063	4.688	11.000
2-1/16	20M	1.125	1.313	2.813	5.750	13-5/8	15M	2.250	2.438	5.625	13.250
2-9/16	10M	0.875	1.042	2.188	4.375	13-5/8	20M	3.000	3.188	7.500	18.125
2-9/16	15M	1.000	1.188	2.500	4.875	16-3/4	5M	1.875	2.063	4.688	9.500
2-9/16	20M	1.250	1.438	3.125	6.250	16-3/4	10M	1.875	2.063	4.688	11.000
3-1/16	10M	1.000	1.188	2.500	5.000	18-3/4	5M	2.000	2.188	5.000	11.250
3-1/16	15M	1.125	1.313	2.813	5.500	18-3/4	10M	2.250	2.438	5.625	14.000
3-1/16	20M	1.375	1.563	3.438	6.750	18-3/4	15M	3.000	3.188	7.500	16.750
4-1/16	10M	1.125	1.313	2.813	5.750	21-1/4	5M	2.000	2.188	5.000	11.750
4-1/16	15M	1.375	1.563	3.438	6.500	21-1/4	10M	2.500	2.688	6.250	15.125
4-1/16	20M	1.750	1.938	4.375	8.375	26-3/4	2M	1.750	1.938	4.375	9.125
5-1/8	10M	1.125	1.313	2.813	6.000	26-3/4	3M	2.000	2.188	5.000	11.000
5-1/8	15M	1.500	1.688	3.750	7.625	30	2M	1.625	1.813	4.063	9.250
7-1/16	10M	1.500	1.688	3.750	7.750	30	3M	1.875	2.063	4.688	11.000
7-1/16	15M	1.500	1.688	3.750	8.375						
7-1/16	20M	2.000	2.188	5.000	11.125						
9	10M	1.500	1.688	3.750	8.500						
9	15M	1.875	2.063	4.688	10.125						
9	20M	2.500	2.688	6.250	13.750						

\* tolerance on tap end thread length:  
 + 1/16 , - 0 inch, See 1.3 Definitions, Length, Tap End Thread.

\*\* tolerance on tap end stud length  
 + 1/8 , - 0 inch

## APPENDIX A

### STUD BOLT LENGTH TABLE FOR 6B FLANGE CONNECTIONS WITH "R" GASKETS

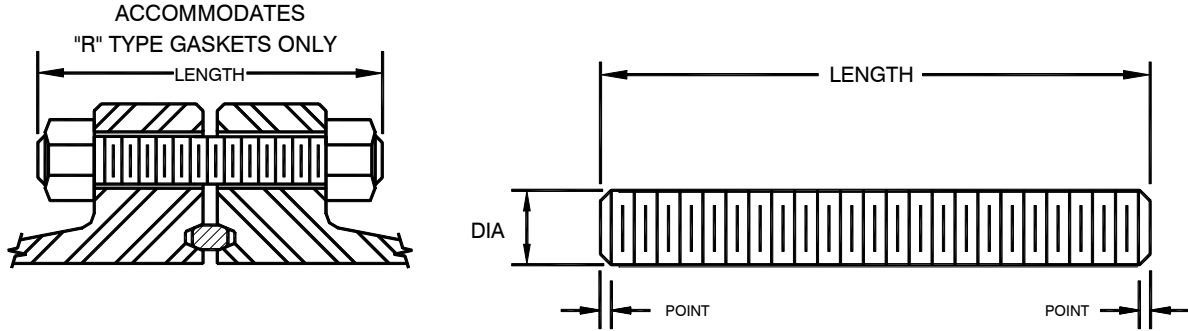

$$\text{LENGTH} = 2(T + t + d) + S + 2(P)$$

- T Total flange thickness.
- t Plus tolerance for flange thickness.
- d Heavy hex nut thickness.
- S Flange face standoff. (with "R" gasket)
- P Point Max. (1.5 X Pitch)

FLANGE SIZE	BOLT DIA.	BOLT DIA.	LENGTH *	FLANGE SIZE	BOLT DIA.	BOLT DIA.	LENGTH *
2-1/16	2M	0.625	4.750	7-1/16	2M	1.000	7.250
2-1/16	3M	0.875	6.250	7-1/16	3M	1.125	8.250
2-1/16	5M	0.875	6.250	7-1/16	5M	1.375	11.000
2-9/16	2M	0.750	5.250	9	2M	1.125	8.250
2-9/16	3M	1.000	6.750	9	3M	1.375	9.250
2-9/16	5M	1.000	6.750	9	5M	1.625	12.250
3-1/8	2M	0.750	5.500	11	2M	1.250	9.000
3-1/8	3M	0.875	6.250	11	3M	1.375	9.750
3-1/8	5M	1.125	7.500	11	5M	1.875	14.000
4-1/16	2M	0.875	6.250	13-5/8	2M	1.250	9.250
4-1/16	3M	1.125	7.250	13-5/8	3M	1.375	10.500
4-1/16	5M	1.250	8.250	16-3/4	2M	1.500	10.500
5-1/8	2M	1.000	7.000	16-3/4	3M	1.625	12.000
5-1/8	3M	1.250	8.000	21-1/4	2M	1.625	11.750
5-1/8	5M	1.500	10.250	20-3/4	3M	2.000	14.500

- \* tolerance on bolt length:
  - + 1/8 , - 0 inch for lengths up to 12 inches.
  - + 1/4 , - 0 inch for lengths over 12 inches.

APPENDIX B

TAP END STUD LENGTH TABLE FOR 6B STUDED FLANGE CONNECTIONS WITH "R" GASKETS

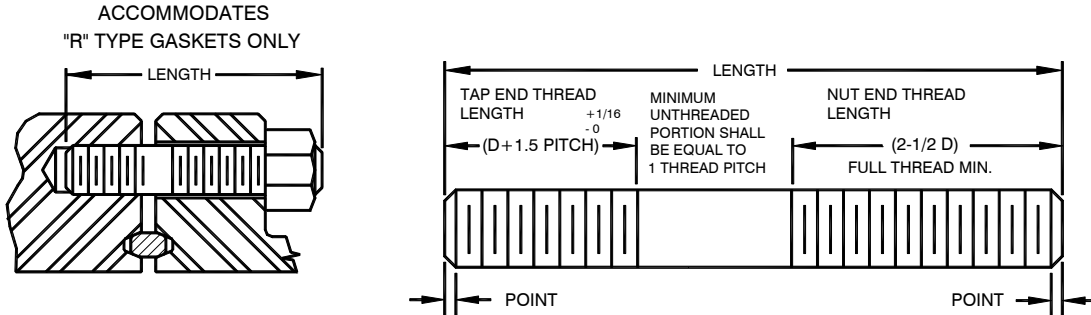

$$\text{LENGTH} = T + t + d + S + P + \text{TL} + \text{RF}$$

- T Total flange thickness.
- t Plus tolerance for flange thickness.
- d Heavy hex nut thickness.
- S Flange face standoff. (with "R" gasket)
- P Point, maximum (1.5 X Pitch)
- TL Tap end thread length, maximum .  
[(one diameter + 1.5 Pitch ) + 1/16 - 0]
- RF Add amount of raised face present on  
studded flanges, if not omitted, to the  
length of studs in table.

FLANGE SIZE	STUD DIA.	TAP END * LENGTH	NUT END LENGTH	** LENGTH	FLANGE SIZE	STUD DIA.	TAP END * LENGTH	NUT END LENGTH	** LENGTH		
2-1/16	2M	0.625	0.761	1.563	3.375	7-1/16	2M	1.000	1.188	2.500	5.000
2-1/16	3M	0.875	1.042	2.188	4.375	7-1/16	3M	1.125	1.313	2.813	5.625
2-1/16	5M	0.875	1.042	2.188	4.375	7-1/16	5M	1.375	1.563	3.438	7.250
2-9/16	2M	0.750	0.900	1.875	3.750	9	2M	1.125	1.313	2.813	5.625
2-9/16	3M	1.000	1.188	2.500	4.750	9	3M	1.375	1.563	3.438	6.375
2-9/16	5M	1.000	1.188	2.500	4.750	9	5M	1.625	1.813	4.063	8.125
3-1/8	2M	0.750	0.900	1.875	3.875	11	2M	1.250	1.438	3.125	6.125
3-1/8	3M	0.875	1.042	2.188	4.375	11	3M	1.375	1.563	3.438	6.625
3-1/8	5M	1.125	1.313	2.813	5.250	11	5M	1.875	2.063	4.688	9.250
4-1/16	2M	0.875	1.042	2.188	4.375	13-5/8	2M	1.250	1.438	3.125	6.250
4-1/16	3M	1.125	1.313	2.813	5.125	13-5/8	3M	1.375	1.563	3.438	7.000
4-1/16	5M	1.250	1.438	3.125	5.750	16-3/4	2M	1.500	1.688	3.750	7.125
5-1/8	2M	1.000	1.188	2.500	4.875	16-3/4	3M	1.625	1.813	4.063	8.000
5-1/8	3M	1.250	1.438	3.125	5.625	21-1/4	2M	1.625	1.813	4.063	8.000
5-1/8	5M	1.500	1.688	3.750	7.000	20-3/4	3M	2.000	2.188	5.000	9.625

\* tolerance on tap end thread length:  
+ 1/16 , - 0 inch, See 1.3 Definitions, Length, Tap End Thread.

\*\* tolerance on tap end stud length  
+ 1/8 , - 0 inch